

# Lynx Hold-Over Reticle Dimensions

Revision 1.1. Copyright ©2009 Lynx Optics.

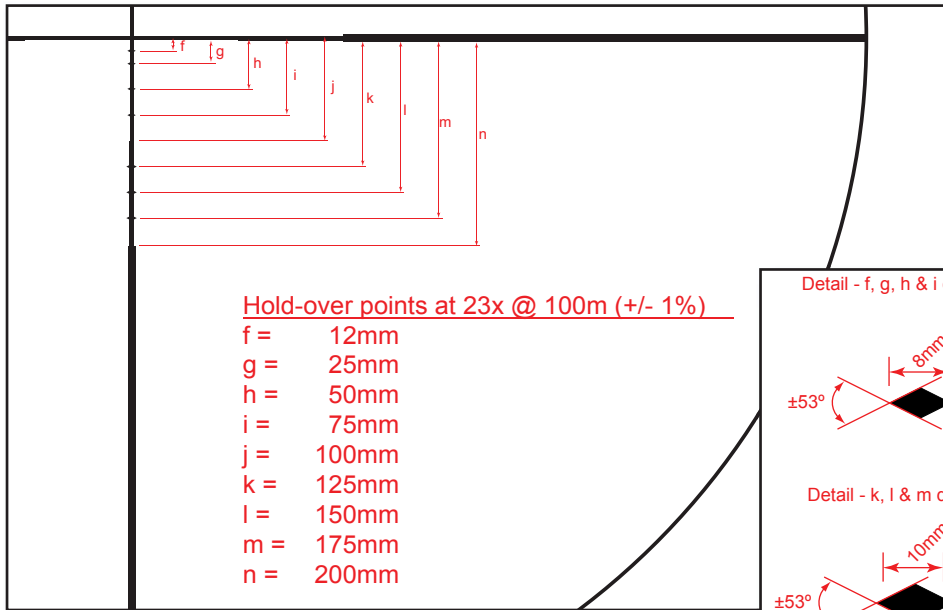

**Hold-over points at 23x @ 100m (+/- 1%)**  
 f = 12mm  
 g = 25mm  
 h = 50mm  
 i = 75mm  
 j = 100mm  
 k = 125mm  
 l = 150mm  
 m = 175mm  
 n = 200mm

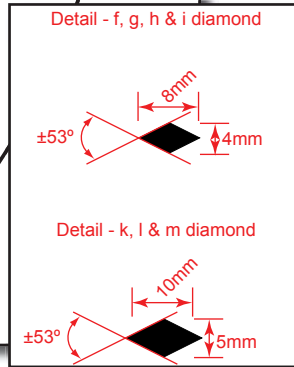

**Hold over points are extremely fine and may be difficult to see if the reticle is not correctly focussed for your eye:**

Turn the eyepiece of the scope anti-clockwise until it stops, then look through the scope at a well lit featureless area such as a nearby wall or cloudless sky - the object of the exercise is to see nothing but the reticle through the scope. You should see a very unsharp reticle. Now without looking through the scope, give the eye bell a couple of clockwise turns at a time. After each adjustment look away from the scope or close your eyes for a moment to relax them and prevent them from bringing the reticle into focus prematurely. This action should be repeated until the reticle immediately appears crisp and sharp at a quick glance. It may be necessary to check and re-adjust the focus if the scope is being used by another person or if your eyesight undergoes significant change.

Millimetres @ 100 metres at magnification 9x to 24x

	9	10	11	12	13	14	15	16	17	18	19	20	21	22	23	24
f	32	28	26	24	22	20	19	18	17	16	15	14	14	13	12	12
g	63	57	52	47	44	41	38	36	33	32	30	28	27	26	25	24
h	126	114	103	95	87	81	76	71	67	63	60	57	54	52	49	47
i	189	170	155	142	131	122	114	107	100	95	90	85	81	77	74	71
j	252	227	207	189	175	162	151	142	134	126	120	114	108	103	99	95
k	316	284	258	237	218	203	189	178	167	158	149	142	135	129	123	118
l	379	341	310	284	262	243	227	213	200	189	179	170	162	155	148	142
m	442	398	361	331	306	284	265	249	234	221	209	199	189	181	173	166
n	505	454	413	379	350	325	303	284	267	252	239	227	216	207	198	189

Millimetres @ 200 metres at magnification 9x to 24x

	9	10	11	12	13	14	15	16	17	18	19	20	21	22	23	24
f	63	57	52	47	44	41	38	36	33	32	30	28	27	26	25	24
g	126	114	103	95	87	81	76	71	67	63	60	57	54	52	49	47
h	252	227	207	189	175	162	151	142	134	126	120	114	108	103	99	95
i	379	341	310	284	262	243	227	213	200	189	179	170	162	155	148	142
j	505	454	413	379	350	325	303	284	267	252	239	227	216	207	198	189
k	631	568	516	473	437	406	379	355	334	316	299	284	270	258	247	237
l	757	682	620	568	524	487	454	426	401	379	359	341	325	310	296	284
m	884	795	723	663	612	568	530	497	468	442	419	398	379	361	346	331
n	1,010	909	826	757	699	649	606	568	535	505	478	454	433	413	395	379

Millimetres @ 300 metres at magnification 9x to 24x

	9	10	11	12	13	14	15	16	17	18	19	20	21	22	23	24
f	95	85	77	71	66	61	57	53	50	47	45	43	41	39	37	36
g	189	170	155	142	131	122	114	107	100	95	90	85	81	77	74	71
h	379	341	310	284	262	243	227	213	200	189	179	170	162	155	148	142
i	568	511	465	426	393	365	341	320	301	284	269	256	243	232	222	213
j	757	682	620	568	524	487	454	426	401	379	359	341	325	310	296	284
k	947	852	775	710	655	609	568	533	501	473	448	426	406	387	370	355
l	1,136	1,022	929	852	786	730	682	639	601	568	538	511	487	465	445	426
m	1,325	1,193	1,084	994	918	852	795	746	702	663	628	596	568	542	519	497
n	1,515	1,363	1,239	1,136	1,049	974	909	852	802	757	717	682	649	620	593	568

Millimetres @ 400 metres at magnification 9x to 24x

	9	10	11	12	13	14	15	16	17	18	19	20	21	22	23	24
f	126	114	103	95	87	81	76	71	67	63	60	57	54	52	49	47
g	252	227	207	189	175	162	151	142	134	126	120	114	108	103	99	95
h	505	454	413	379	350	325	303	284	267	252	239	227	216	207	198	189
i	757	682	620	568	524	487	454	426	401	379	359	341	325	310	296	284
j	1,010	909	826	757	699	649	606	568	535	505	478	454	433	413	395	379
k	1,262	1,136	1,033	947	874	811	757	710	668	631	598	568	541	516	494	473
l	1,515	1,363	1,239	1,136	1,049	974	909	852	802	757	717	682	649	620	593	568
m	1,767	1,590	1,446	1,325	1,223	1,136	1,060	994	936	884	837	795	757	723	691	663
n	2,020	1,818	1,652	1,515	1,398	1,298	1,212	1,136	1,069	1,010	957	909	866	826	790	757